

BLOCKBUSTER INC.

OPERATORS AND OWNER'S MANUAL

FOR MODELS

1412, 1412+, 1520, 1520+, 1520+ HP, 1820, 1820+, 2220, & 2222

**BLOCKBUSTER INC.
800 E. 7th Street
Washington, IA 52353
888-775-4883**

TABLE OF CONTENTS

INTRODUCTION..... 3
MANUFACTURER'S INTENDED PURPOSE..... 4
STANDARD SAFETY SIGNS..... 5-6

OPERATING

TRANSPORTING THE PROCESSOR..... 7-8
SAFETY INSTRUCTIONS..... 8-9
SAFETY PROTECTION..... 9
MACHINE SET-UP & STABILITY..... 9-10
PRIOR TO OPERATION 10
OPERATING TIPS..... 10
PUTTING INTO SERVICE 10-11
ENGINE OPERATION 11
HYDRAULIC CHAINSAW OPERATION..... 12-14
SAFE HANDLING & FIRE PREVENTION 15

CONTROLS

ENGINE CONTROL PANEL, ALL APPLICABLE MODELS..... 16
MODEL 22-22 - LEVER CONTROLS, SETUP VALVE..... 17-18
MODEL 22-20 & 1820+ - LEVER CONTROLS 19
MODEL 18-20 - LEVER CONTROLS 20
MODEL 1412, 1412+, 1520, 1520+, 1520+HP - LEVER CONTROLS..... 21
HYDRAULIC PRESSURE SETTINGS..... 22-24

MAINTENANCE & GENERAL SERVICING

ROUTINE SERVICE INTERVALS..... 25
LUBRICATION POINTS..... 25-28
MAINTENANCE & GENERAL SERVICING..... 29-30
REPAIRS & ADJUSTMENTS..... 30-31
CLEANING..... 31
STORING..... 31
HANDLING WASTE PRODUCTS..... 31-32
TROUBLESHOOTING CHART..... 32-35
STANDARD MODEL EQUIPMENT & SPECIFICATIONS CHART..... 36-39

INTRODUCTION

This manual is an important part of your machine and should always remain with the machine.

Reading and understanding your Blockbuster Operator's Manual will help you and others avoid personal injury or damage to the machine.

The information given in this manual will provide the operator with the safest and most effective use of the machine.

Knowing how to operate this machine safely and correctly will allow you to train others who may operate this machine.

Sections in your operator's manual are laid out in such a way to help you understand all the safety messages and learn the controls so you can operate this machine safely.

NO TOOLS ARE REQUIRED FOR SETTING UP THIS MACHINE.

This manual contains information about your machine. Please make sure you're referring to the relevant sections that apply specifically to your model.

Measurements in this manual are U.S. customary units and their metric equivalents are in parenthesis. The RIGHT-HAND side of the machine is the side where the operator controls are located.

Record identification numbers below. Be sure to record all the numbers to help in tracing the machine if it is stolen. You also need to give these numbers to your dealer when you order parts.

Date of Purchase:

Dealer Name:

Phone:

Engine Serial Number:

Machine Serial Number:

Manufacturer's Intended Purpose or Use

Models 22-22, 22-20, 18-20+, 18-20, 15-20+ HP, 15-20+, 15-20, 14-12+ and 14-12 Firewood Processors are designed to cut logs into lengths that can be split into firewood suitable for use in fireplaces and wood burners. Logs ranging in various lengths (See Standard Model Equipment & Specifications Chart) can be loaded onto the machine using a lift truck or grappling device. Logs of various diameters (See Standard Model Equipment & Specifications Chart) can be cut. Logs are first cut into desired lengths (See Standard Model Equipment & Specifications Chart) and are then split into firewood using four, six, eight, or twelve-way splitting heads.

Models 22-22, 22-20, 18-20+, 18-20, 15-20+ HP, 15-20+, 15-20, 14-12+ and 14-12 Firewood Processors are designed to process logs only and can cope with seasoned or unseasoned hard and softwoods with or without bark. These firewood processors are designed for outside use only, in well-ventilated areas. They can be used in all kinds of weather and temperature.

The machine cannot handle bent logs with overall extremities that are greater than the width of the trough into which they must be loaded. Logs must have clean cut ends for feed mechanisms to get a good register.

The chain saw should be adequately lubricated by adjusting the saw chain oil valve. The attached, hydraulic chain saw uses a state of the art, 18H micro-chisel chain, which was specifically designed for use in most mechanical harvesters. The chain delivers top performance with a minimum amount of maintenance.

Manufacturer's Contact Information:

Blockbuster, Inc.
800 E 7th Street 869
Washington, Iowa 52353

Office Toll Free: 1-800-775-4883

www.blockbuster-inc.com

STANDARD SAFETY SIGNS

Read and recognize all standard safety signs. Be alert to the potential for personal injury with each of these signs. There are several safety signs located on your Blockbuster. Keep all safety signs clean and visible. Contact your dealer if any warning signs need replacement.

The manufacturer stresses that the new owner review all safety signs prior to the operation of their piece of equipment. The identification and acknowledgement of these signs will assist in the prevention of serious injury or death to the operator or any bystanders.

A sample of signs you will see on your machine are shown below.

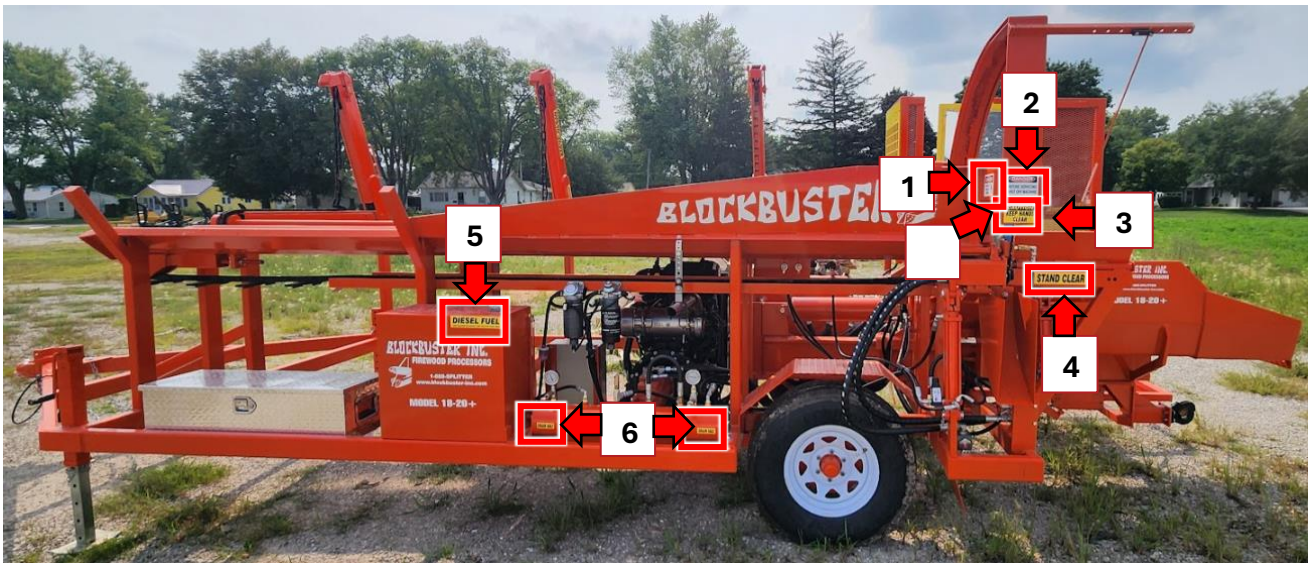

1



3



5



2



4



6



7



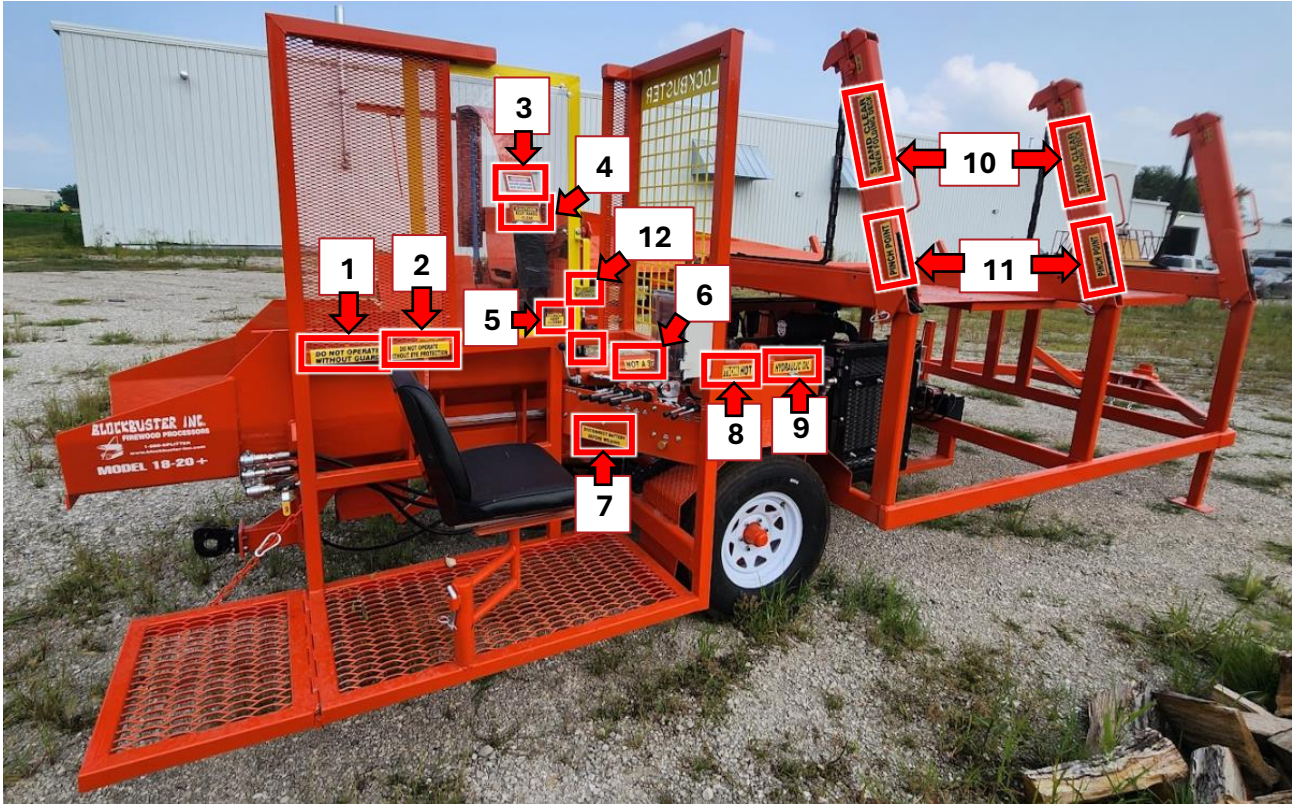

1

DO NOT OPERATE WITHOUT GUARD

2

DO NOT OPERATE WITHOUT EYE PROTECTION

3

DANGER
BEFORE SERVICING SHUT OFF MACHINE

10

STAND CLEAR WHEN FOLDING DECK

4

CAUTION
KEEP HANDS CLEAR

5

CAUTION
KEEP CLOSED

6

NOT A STEP

11

PINCH POINT

7

DISCONNECT BATTERY BEFORE WELDING

8

CAUTION HOT

9

HYDRAULIC OIL

12

WARNING
SAFETY HAZARD
KEEP ALL SHIELDS, DOORS AND COVERS IN PLACE

TRANSPORTING THE PROCESSOR

Prior to towing the processor:

- Ensure trailer ball coupling mechanism is operational and in good working condition.
 - Models 14-12, 14-12+, 15-20, 15-20+, and 15-20+ HP will utilize a 2” trailer ball.
 - Models 18-20, 1820+, 22-20, and 2222 will utilize a 2 5/16” trailer ball.
- Check lugnut torque after the first 50 miles and periodically thereafter. (110 ft. Lbs.)
- Trailer tow chains are in good condition and hooked properly to the towing vehicle.
- The tires are in good condition and inflated to the specifications listed on the tire.
- Trailer brakes are hooked up and operational.
- Running lights are operational and in working condition. (see below for instructions)
- All items are securely stored and fastened to the machine.
 - Toolbox lid is latched.
 - Keys are removed from the ignition and properly stored.
 - The operator’s seat is securely pinned.
 - Deck legs are properly stowed and secured.
 - The operator’s cab door and windows are shut/locked. (If equipped)
- The attached elevator is properly retained with safety chains. (If equipped)
- The leveling stiff legs and jacks are also used as tongue jacks for connecting and disconnecting from a towing vehicle.
- The machinery is equipped with an axle and hitch and is meant to be towed, not lifted.
- **THIS MACHINE SHOULD NEVER BE LIFTED.**
- The towing device to be used for each model is listed in the Standard Model Equipment & Specifications Chart at the end of this manual.
- The towing vehicle used should be classified to meet or exceed the vehicle weight and tongue weight of the specific piece of equipment being towed. The specific equipment's vehicle weight and tongue weight is detailed in the Standard Model Equipment & Specifications Chart at the end of this manual.
- National road traffic regulations for lamps, headlights, rear lights, flashing lights, and reflectors must be followed when the machine is transported.
- Each Blockbuster Firwood Processor comes with a Magnetic LED Wireless Towing Light Kit. This kit is stored in the toolbox of each new processor.
 - Magnetic LED Wireless Towing Light Kit operating instructions.
 - Connect the transmitter to the four-pin connector that is located on the firewood processor, making sure that the transmitter is secured to the body or chassis of the processor.
 - Fasten the lights to the processor to where they are visible to motorists that are following. Use the included lanyards to fasten the lights to the processor.
 - Press the Power button at the top of each light TWICE to turn it on. Each light will flash briefly when turned on.
 - The Towing Light Kit is now ready for use. It will automatically illuminate when running lamps, brake pedal, or turn signals in the towing vehicle are

used.

- Test each vehicle's function before towing, making sure that tow lights respond properly.

OPERATING

Safety Instructions:

- Read and understand this Operator's Manual and all labels on the Blockbuster before attempting to start and operate this equipment.
- The Blockbuster was designed to process logs into firewood and should **NEVER** be used for anything other than what it was specifically designed for.
- **DO NOT** cut logs that are outside the manufacturer's dimensional specifications as listed in the Standard Model Equipment & Specifications at the end of this manual.
- For the operator's safety, **DO NOT** remove or modify equipment guards.
- Each model's total weight, tongue weight, and force in Pounds and Newtons is referenced in the Standard Model Equipment & Specifications.
- **NEVER** let unauthorized personnel operate the machinery.
- **DO NOT** operate the machinery under the influence of alcohol or drugs.
- **DO NOT let personnel ride on the machinery during transport, regardless of distance.**
- National road traffic regulations for lamps, headlights, rear lights, flashing lights, and reflectors must be followed when the machine is transported.
- The Manufacturer recommends that Blockbuster operation is for daylight hours or in conjunction with sufficient artificial lighting.
- Blockbuster operation is intended for outside and well-ventilated use only.
- **DO NOT MODIFY THE MACHINE IN ANY WAY. UNAUTHORIZED MODIFICATIONS MAY IMPAIR THE FUNCTION AND/OR SAFETY OF THIS MACHINE AND WILL VOID MANUFACTURE WARRANTY**
- Hydraulic pressurized hoses are designed to prevent crushing or pinching by moving parts. To enhance operator safety, the manufacturer may also provide a canvas covering for certain hydraulic hoses as an additional safeguard.
- **NEVER** leave any piece of machinery unattended while running.
- **Safe distance for observers is a minimum of 50 feet (15.24m) from the work area.**
- Always **BE ALERT** and **ATTENTIVE** when operating any machinery.

Safety Protection:

- **Safe distance for observers is a minimum of 50 feet (15.24m) from the work area.**
- Due to the operator running the machine in a standing position, the 14-12 & 15-20 models have seats that are intended for short term use and are not designed to supply lumbar support.
- Do not wear loose, torn, or bulky clothing around this machine. Clothing could catch on to the machine and result in personal injury.
- **Ensure EYE PROTECTION, EAR PROTECTION, and PROPER FOOT PROTECTION are worn when operating the Blockbuster.**
- The maximum decibel level, at the controller's station, for this Blockbuster model does not exceed 84dB(A). The manufacturer strongly recommends the use of ear protection even though this machine is meant for outside use only.

Machine Set-Up & Stability:

- It is important to keep the Blockbuster as stable as possible when setting up for operation. The machine should be placed on a level area and the use of the stiff legs will assist in making the machine fully stable. The Blockbuster is not designed to run on hills, slopes, or any unstable ground.
- Depending on your model, the leveling of the Blockbuster is done with manual or hydraulic stiff legs or jacks. Blockbusters are equipped with large metal plates on each stiff leg, proportional to each machine's weight, for extra stability and safety. Operators should review the machines controls pictured in the manual and refer to the manual "Putting into Service" section for further instructions.
- If your model is equipped with handles on the log support, these should be utilized to ensure an excellent grip is maintained for the operator's safety while setting up this equipment.
- **DO NOT let personnel ride on the machinery during transport, regardless of distance.**
- **Safe distance for observers is a minimum of 50 feet (15.24m) from the work area.**

Prior to Operation:

- With the machine turned off, inspect that the chain is in good visible condition and properly tensioned. (Refer to guide bar maintenance on page 11)
- All hydraulic lever handles are tensioned properly and function accordingly.
- Operator's guard (polycarbonate display window) is present with no defects.
- The saw bar guard is present.
- **NO ASSEMBLY OR ADJUSTMENTS ARE REQUIRED PRIOR TO OPERATION.**
- Contact your Dealer or the Manufacturer with operations questions.

Operating Tips:

- Keep the machine's engine idling for at least five minutes:
 - Before running at operating speeds
 - Before shutting off the engine.
- This allows the engine and the hydraulic fluid to adequately warm up and cool down.
- **BE AWARE** that colder temperatures can affect the amount of idling time needed for warming up and cooling.

Putting Into Service:

- Ensure your Blockbuster is positioned on level ground and in a well-ventilated area.
- Crank the stabilizing leg into place. Manually lower the opposite stabilizing leg so the equipment is level.
- Unhook the equipment from the towing hitch.
- Depending on your model, manually, or hydraulically, remove storage pins on stiff legs to

unfold and lower log deck and lock them into place.

- Operators should ensure hydraulic components are safe and secure for operation, and no fluid leaks are evident.
- Ensure all fluid levels (engine oil, coolant, hydraulic reservoir) are in acceptable ranges
- Ensure all guards and other protective equipment are in place and secure.
- Clear the work area of objects that might be hazardous to the operation.
- Start the engine and begin loading the log deck for operation.
- Keep unauthorized personnel & animals at least 50 feet (15.24m) out of the work area. Stop the machinery immediately if anyone, or anything, enters the work area.

Engine Operation:

- Refer to the Engine Manual for the engine manufacturer's specific information pertaining to starting and stopping the engine.

Hydraulic Chain Saw Operation:

The 18H, state of the art chain, has an aggressive, Micro-Chisel cutter with .050" (1.27mm) depth gauge setting, an extra-thick .080"-gauge drive links, more chassis material below the rivet holes on cutters and tie straps, more material in the drive link tang. This chain has maximum performance and maximum durability.

DRIVE SPROCKET INSPECTION

A heavily worn drive sprocket, no matter which type, can cause problems with the saw bar. When you change the harvester chain, inspect the sprocket and replace it if necessary. Replace the drive sprocket when the worn surface is more than .3mm. Inspect and replace dowel pins if they are loose or missing. The harvester chain will be damaged instantly if a worn drive sprocket is used.

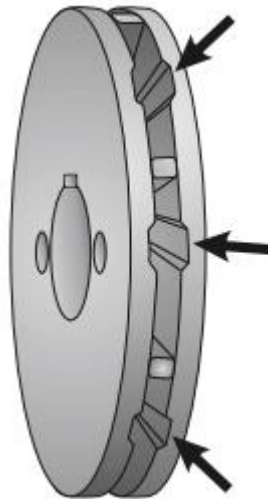

BAR DRESSING PROCEDURE

Dressing may be necessary at routine intervals to maintain performance and prolong the life of the bar and chain.

- Clean the bar groove: Use a groove cleaner to remove any sawdust, dirt or debris from the bar groove. This is crucial for proper lubrication and chain movement.
- File the bar rails: Use a flat file or bar dressing tool with a guide to keep the file at a 90-degree angle to the bar. File the top rails to remove any burrs and bring them back to a flat, even surface. The goal is to make sure the top of the rails are level and the entire top surface is smooth.
- Check and clean the oil hole: Ensure the oil hole on the bar is not clogged. If it is, clean it out, as lack of lubrication will damage the bar and chain.

TENSIONING OF CHAIN

- Chain tension should be checked routinely. Always shut the machine off before checking chain tension. Always wear gloves while checking chain tension.
- To check tension, lift up on the chain in the middle of the bar on either the driver or driven side. The chain should pull up slightly, but the chain links should stay in the bar as shown below. If you let go quickly, the chain should snap right back into place.

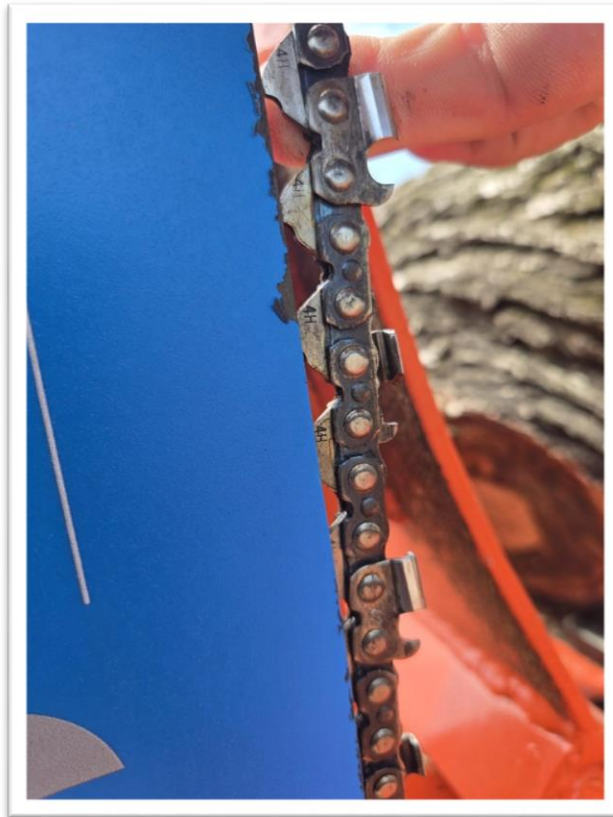

- To tighten the chain, loosen both nuts on the bar using a 9/16" wrench. Using a 1/2" wrench, tighten the adjuster nut by turning it clockwise. Once the chain is at the desired tension, tighten the 9/16" hex nuts on the bar.
- To loosen the chain, loosen both nuts on the bar using a 9/16" wrench. Using a 1/2" wrench, loosen the adjuster nut by turning it counterclockwise. Once the chain is at the desired tension, tighten the 9/16" hex nuts on the bar.

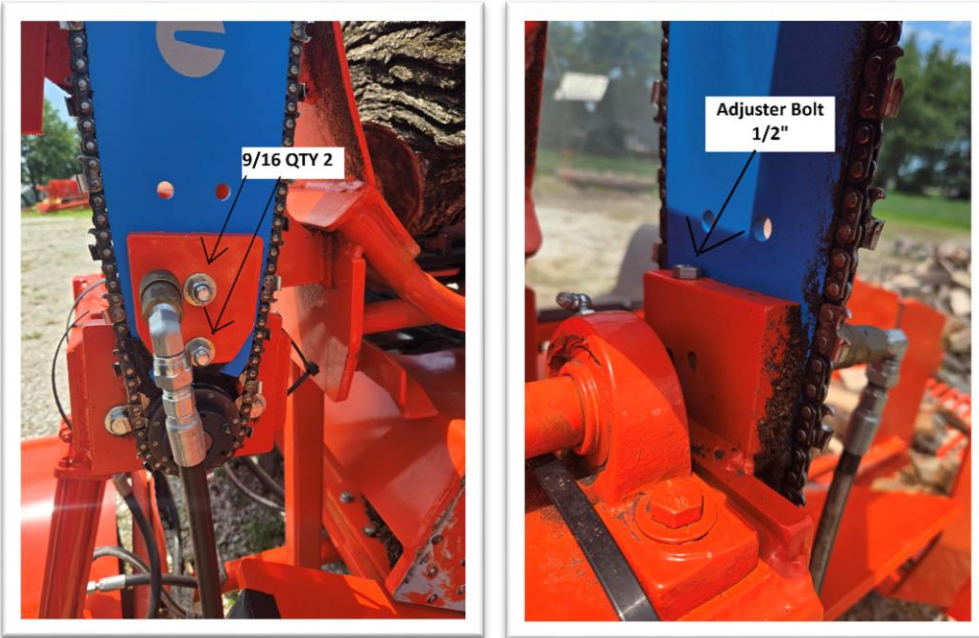

AUTO TENSION BAR & CHAIN INSTALLATION (IF EQUIPPED)

- Always ensure the machine is off and the ignition key is removed from the ignition when performing any adjustments to the bar or chain.
- **TO PREVENT DAMAGE, ALWAYS ENSURE THAT THE SAW BAR IS INSTALLED WHEN THE HYDRAULIC LINE IS HOOKED UP.**
- Insert saw bar fully with mount in vertical position. Ensure the sprocket is in line with the saw bar.
- Place the retract tool on the upper chain catcher and over lower chain catcher. Retract tensioner and push detent pin as shown in figure 1.
- Install chain. Retract tensioner with the tool and the detent will automatically retract. Release pressure on the tool and remove.
- Attach hoses, bar oil outside fitting, and inside fitting. See figure 2.
- **DO NOT TIGHTEN OR LOOSEN THE BOLTS FOR THE CHAIN CATCHER AT ANYTIME.**

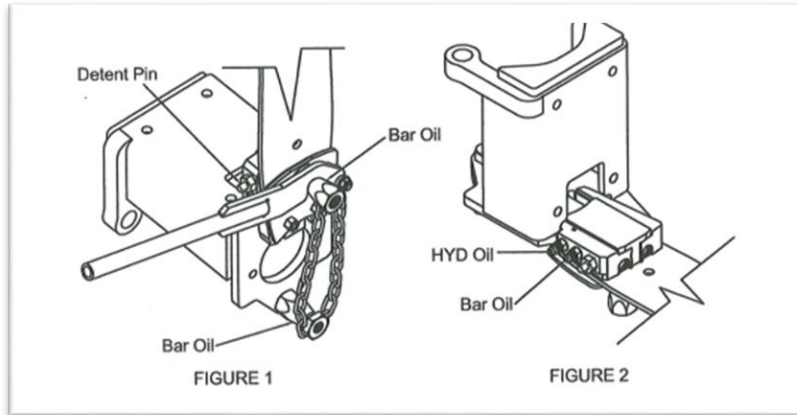

CHAIN BREAK-IN

- It is critical that the chain is broken in properly.
 - Make sure the new chain is well lubricated.
 - Install and tension.
 - Run saw at partial throttle for about 3 minutes and re-tension.
 - Resume operation for 30 minutes.
 - Perform one last tension check and adjust if necessary.
- Manufacturer recommends the chain be lubricated prior to use.
- If necessary, the chain tension should be adjusted after the first several minutes of use.

SHARPENING OF CHAIN

1. Clean all oil and grease from chain.
2. Inspect the chain for the following:
 - Proper installation of tie straps and drive links.
 - Cracked or broken cutters, cutter top plates, or tie straps.
 - Bent, cracked, or burred drive links.
 - Abnormal chain wear.
 - Wear patterns on the chain that may indicate a worn bar or sprocket.
 - Any loose rivets.
3. Use the sharpening specifications for the Micro-Chisel chain listed below:
 - Chain Type - 18H
 - Gauge - .080"
 - Pitch - .404"
 - 7/32" Round File
 - 3/16" Grinding Wheel
 - 7/32" Assembled File Guide
 - .050" Depth Gauge
 - Depth Gauge File

4. After sharpening the chain adjust the depth gauge to the number stamped on each chain.
5. When completed, blow any particles off then rinse in solvent or diesel oil.
6. Heavily lubricate chain with oil prior to use.

GUIDE-BAR MAINTENANCE

- Check for a loose chain before and during use.
- Clean bar groove daily when being used for extended periods.
- On a periodic basis do the following:
 - Clean oil holes.
 - Check bar groove and chain for straightness.
 - Keep the rail clean and operational.

Safe Handling & Fire Prevention:

- Always be careful and never hurry while operating a piece of machinery.
- **WARNING** - It is not recommended to run the engine in an enclosed area. Work should be performed outside in a well-ventilated area. Engine exhaust can be very harmful if allowed to accumulate.
- Be aware of any leaks of flammable fluids to avoid a fire.
- To prevent a fire, do not expose any dry, dusty material, oil and other combustibles to the muffler or exhaust. Keep the engine and muffler clean at all times.
- Ensure all flammable fluids and liquids are stored away from the engine.
- Always stop the machine before refueling or lubricating.
- Refuel in well-ventilated areas. Wipe up any spilled fuel or lubricants prior to operation.
- Do not mix gasoline or alcohol with diesel fuel. This mixture can cause a fire.
- Do not smoke or allow flames or sparks in the work area.
- Escaping hydraulic fluid which is under pressure has sufficient force to penetrate skin causing serious personal injury. Always use caution when working with fluids under pressure.
- Hydraulic pressurized hoses have been designed in a way that moving parts cannot crush or pinch them. Therefore, if deemed necessary, the manufacturer may guard various hydraulic hoses with a canvas covering for the operator's protection.
- Be cautious of the saw dust created and its potential to ignite as it may have oil in it.

CONTROLS

ENGINE CONTROL PANEL

MODELS: 22-22, 22-20, 18-20+, 18-20, and 15-20+HP

Read and recognize the operating controls. Be alert to the potential for personal injury while operating this machine. Consult the Operator's Manual or contact your dealer if you have further questions.

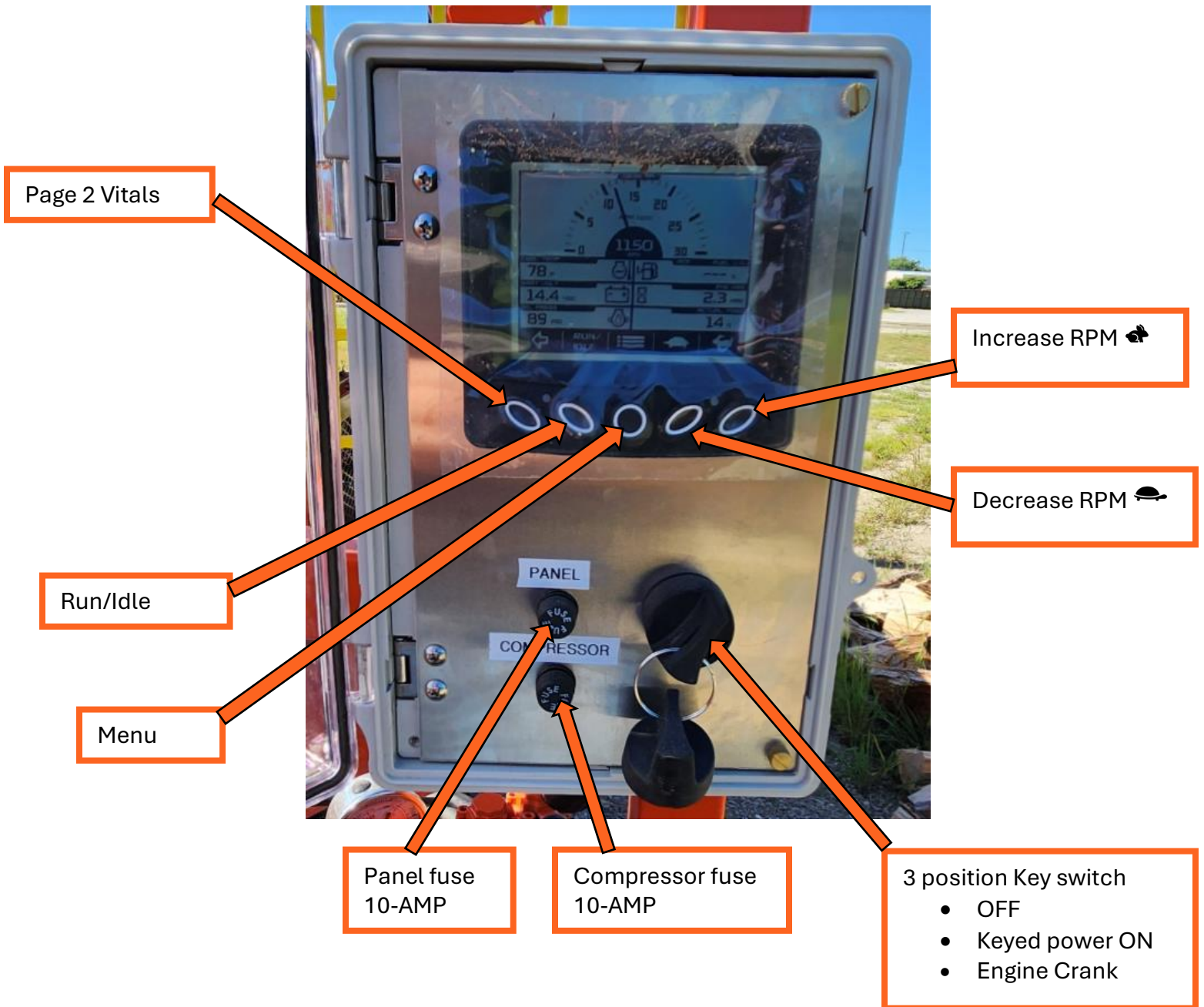

MODEL 22-22 LEVER CONTROLS

Familiarize yourself with the operating controls and remain vigilant about the potential for personal injury while using this machine. If you have any questions or need clarification, please refer to the Operator's Manual or reach out to your dealer for assistance.

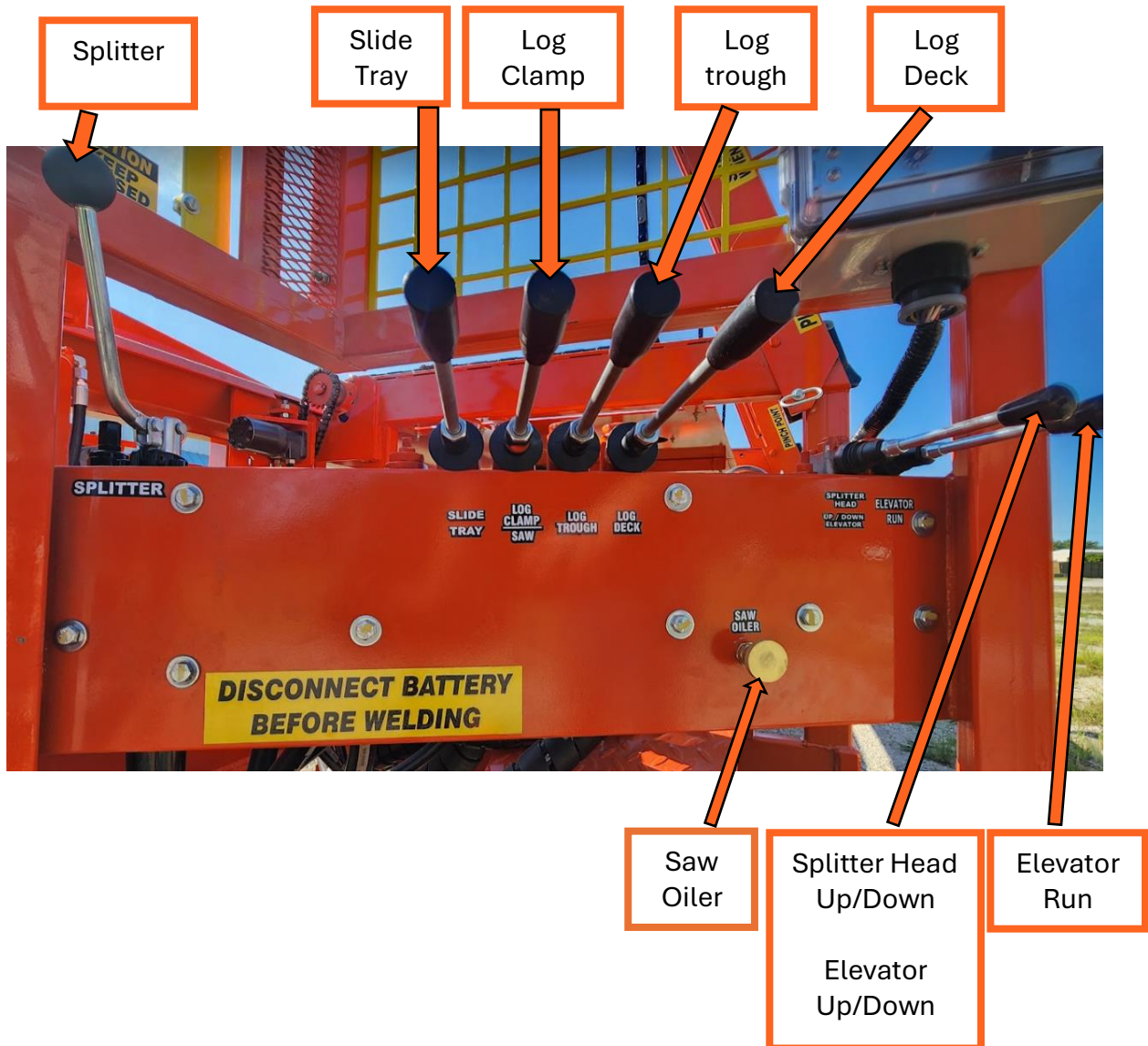

MODEL 22-22
ADDITIONAL LEVER CONTROLS (SETUP VALVE)

Read and recognize the operating controls. Be alert to the potential for personal injury while operating this machine. Consult the Operator's Manual or contact your dealer if you have further questions.

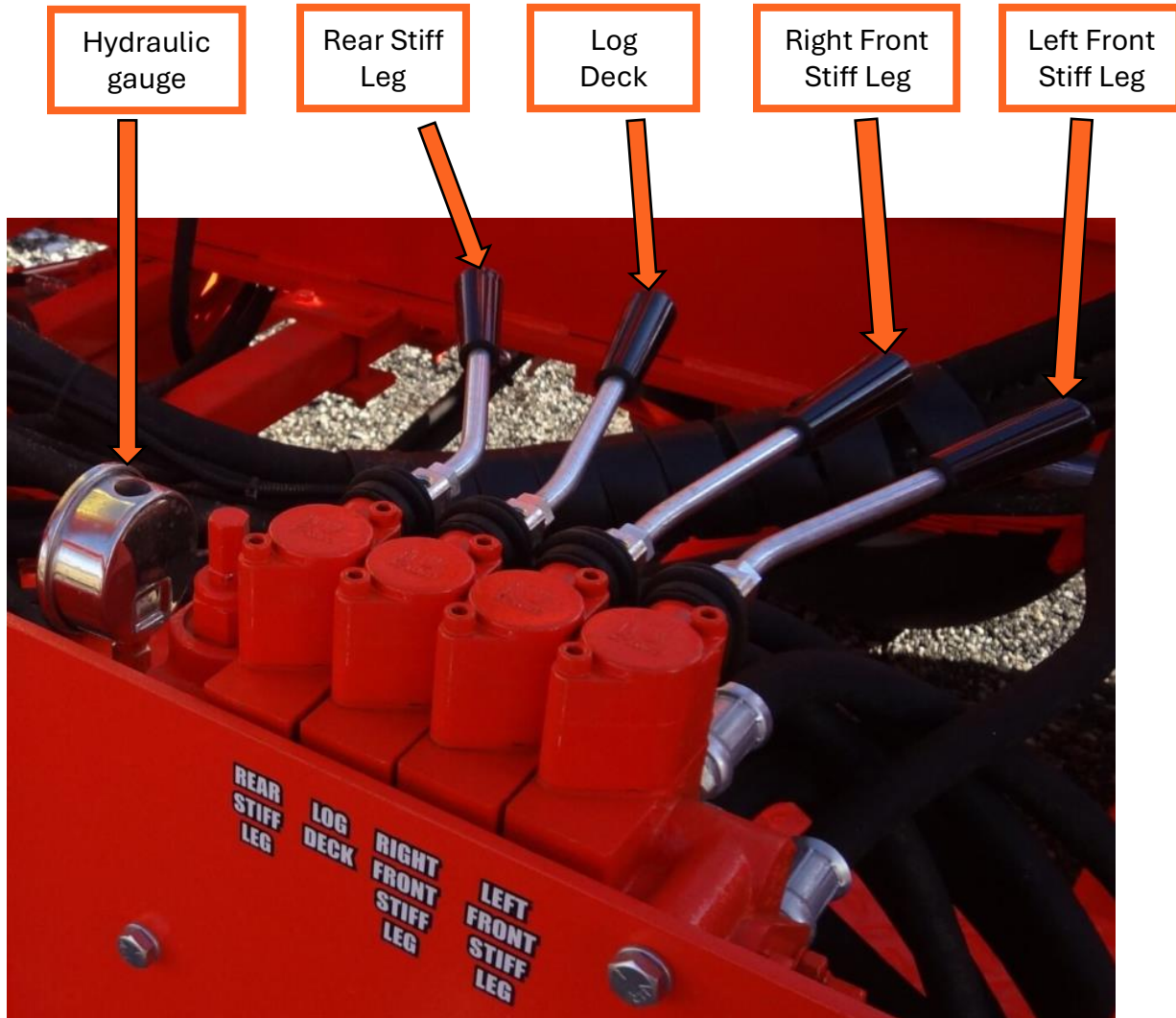

MODEL 22-20 LEVER CONTROLS

Read and recognize the operating controls. Be alert to the potential for personal injury while operating this machine. Consult the Operator's Manual or contact your dealer if you have further questions.

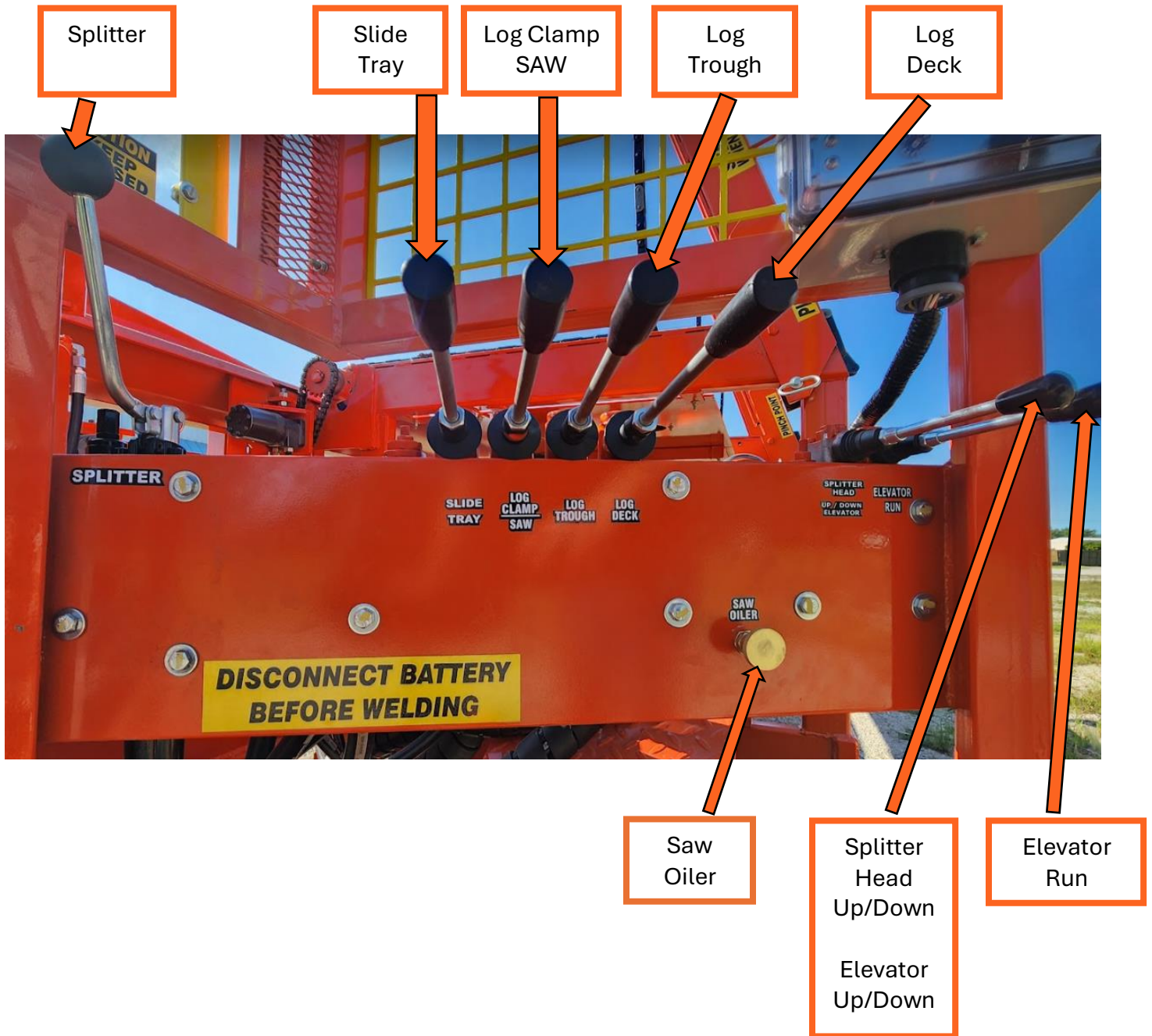

MODEL 18-20 LEVER CONTROLS

Read and recognize the operating controls. Be alert to the potential for personal injury while operating this machine. Consult the Operator's Manual or contact your dealer if you have further questions.

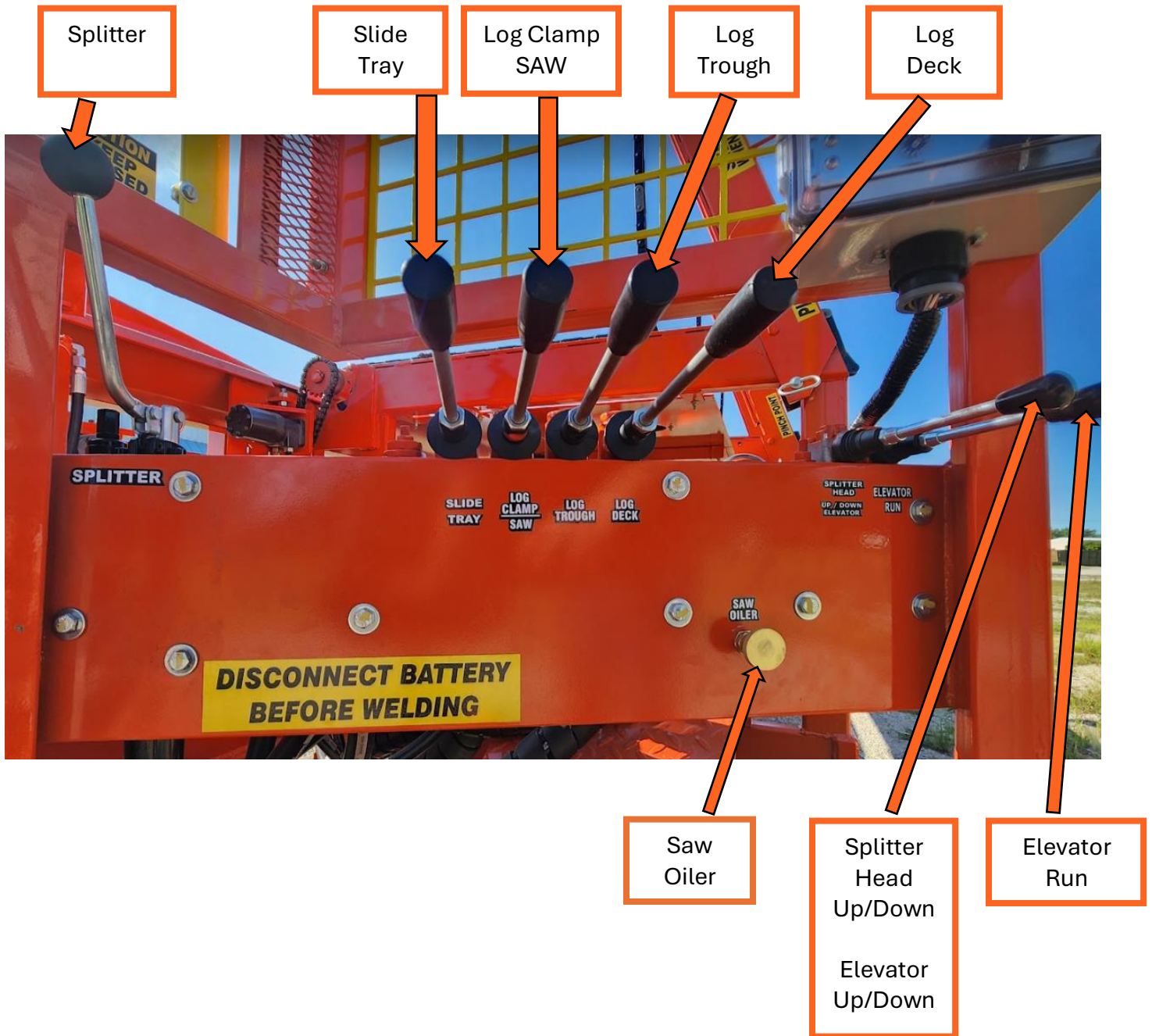

**MODEL 14-12, 14-12+, 15-20, 15-20+, and 15-20+ HP
LEVER CONTROLS**

Read and recognize the operating controls. Be alert to the potential for personal injury while operating this machine. Consult the Operator's Manual or contact your dealer if you have further questions.

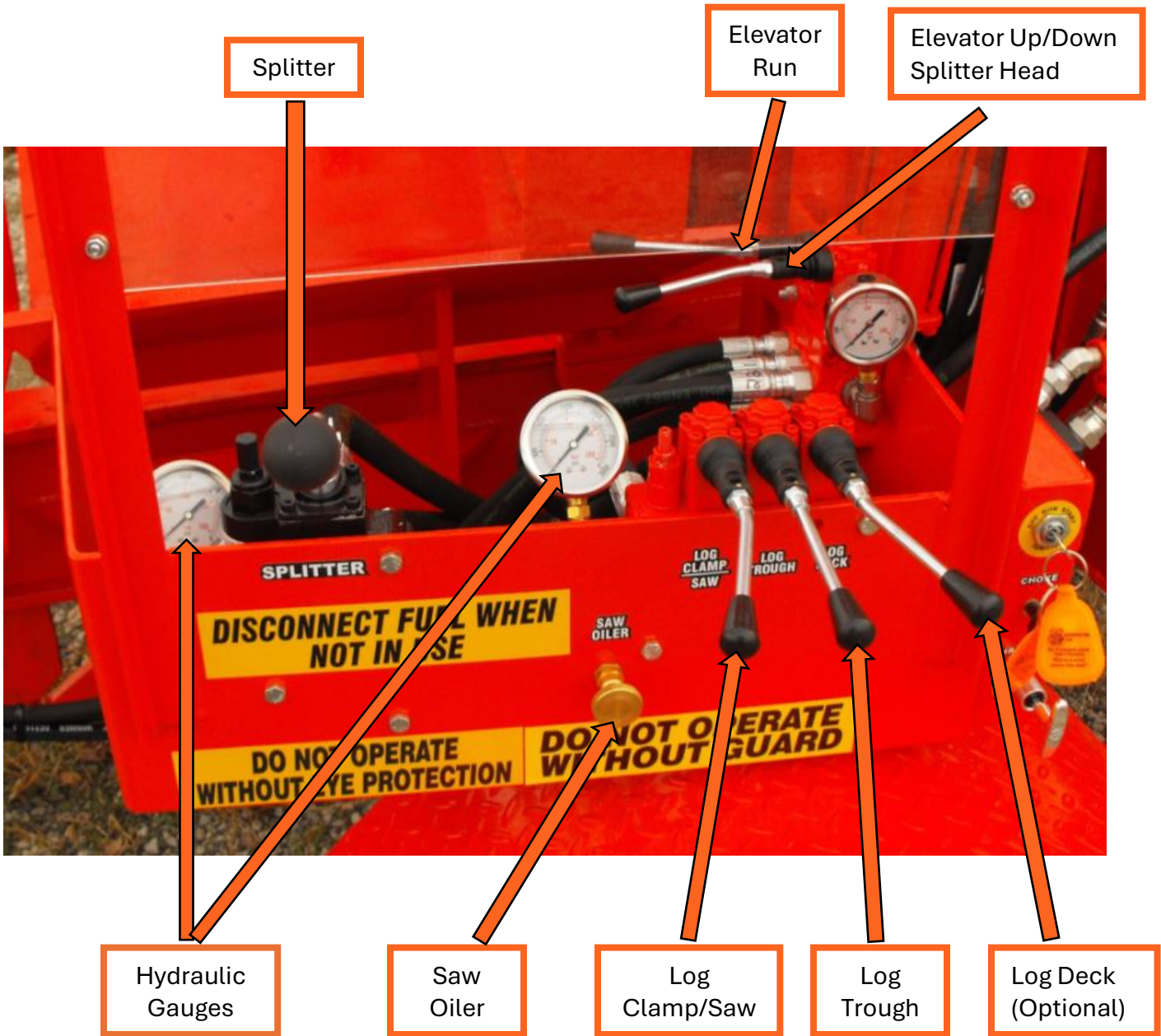

HYDRAULIC PRESSURE SETTINGS

ALWAYS USE CAUTION WHEN OPERATING EQUIPMENT

Pressure settings are pre-set at the factory and should require NO adjusting. Resetting pressures on a correctly working processor could result in improper operation. Contact your dealer for any issues pertaining to pressure settings. Make sure the engine IS NOT running when making any adjustment. The hydraulic cylinders have a pressure- controlled by-pass. The hydraulic pressurized hoses have been designed in a way that moving parts cannot crush or pinch them.

ALL MODELS REQUIRE THE FOLLOWING SETTINGS

Main Splitter Pressure (All Models) (Hold handle down until maximum pressure is achieved)	2,400 PSI
Clamp/Saw, Trough, Deck & Stiff Leg Valve (All Models) (Hold saw lever up until maximum pressure is achieved)	1,800 PSI
Elevator Valve (Model 18-20 & 15-20) (Hold up/down lever down until maximum pressure is achieved)	800-900 PSI
Elevator Valve (Model 22-22, 22-20) (Hold up/down lever down until maximum pressure is achieved)	900 PSI

Model 14-12, 14-12+, 15-20, 15-20+, 1520+HP

1. Take your readings from the gauge on clamp/saw valve.
2. Run engine to operating speed (Gas engine 3600 RPM on Model 14-12, 14-12+, 15-20, and 15-20+) & (2,400 rpm for diesel engines)
3. To set the clamp pressure, bring clamp all the way down. Feather clamp/saw lever until saw bar starts coming down. Look at gauge; pressure needs to be 800 PSI when bar moves. If not correct, stop engine and adjust. For more pressure turn the pressure relief on clamp cylinder clockwise, for less pressure turn counterclockwise.
4. To set the saw pressure. Saw a 12-inch round log. If the chain stops when contacting the log, stop engine, turn pressure relief counterclockwise 1/16 to 1/8 turn. Gauge on saw cylinder should be approximately 50 Psi while cutting. Restart machine and saw the log. Repeat if necessary. If the saw does not cut all the way through the log, stop engine and turn pressure relief on saw clockwise 1/16 to 1/8 turn. Restart machine and saw the log, repeat if necessary.

Model 18-20

1. Take your readings from the gauge on clamp/saw valve.
2. Run Doosan diesel engine to an operating speed of 2400 RPM.
3. To set the clamp pressure, bring clamp all the way down. Feather clamp/saw lever until saw bar starts coming down. Look at gauge; pressure needs to be 800 PSI when bar moves. If not correct stop engine and adjust. For more pressure turn the pressure relief on clamp cylinder clockwise. For less pressure turn counterclockwise.
4. To set the saw pressure requires two people. Saw a 12-inch round log. While cutting, person two watch the gauge on the saw cylinder. Pressure should be 180-190 while cutting. If the chain stops when contacting the log, stop engine, turn pressure relief counterclockwise 1/16 to 1/8 turn. Restart machine and saw the log, repeat if necessary. If the saw does not cut all the way through the log, stop engine and turn pressure relief on saw clockwise 1/16 to 1/8 turn. Restart machine and saw the log, repeat if necessary.

Model 22-22, Model 22-20, & 18-20+

1. Take your readings from the gauge on still leg valve.
2. Run engine to operating speed of 2400 RPM.
3. To set the clamp pressure, bring clamp all the way down. Feather clamp/saw lever until saw bar starts coming down. Look at gauge; pressure for Auto tensioner needs to be 1200 PSI when bar moves. If not correct stop engine and adjust. For more pressure turn the pressure relief on clamp cylinder clockwise. For less pressure turn counterclockwise.
4. To set the saw pressure requires two people. Saw a 12-inch round log. While cutting, person two watch the gauge on the saw cylinder. Pressure should be 180-190 while cutting. If the chain stops when contacting the log, stop engine, turn pressure relief counterclockwise 1/16 to 1/8 turn. Restart machine and saw the log. Repeat if necessary. If the saw does not cut all the way through the log, stop engine and turn pressure relief on saw clockwise 1/16 to 1/8 turn. Restart machine and saw the log, repeat if necessary.
5. Clockwise - raises pressure
6. Counterclockwise - lowers pressure
7. MSL pressure setting 1500-2400 (saw motor power, not speed)

Routine Service Intervals

Daily (every 8 hours)

- Check all fluid levels
 - Engine fuel level
 - Engine oil
 - Engine coolant level
 - Hydraulic Fluid
- Check condition of saw chain and ensure proper tension
- Inspect the bar saw for any defects and to ensure its straight.
- Check for proper tension of infeed conveyor chain and live deck chains. Adjust if needed.
- Inspect wedge(s) for any damage or cracked welds.

Weekly (every 40 hours)

- Lubricate the following: (Reference next page for locations)
 - Infeed conveyor chain bearings (3 zerks)
 - Live deck chain bearings (zerks, depending on model)
 - Saw pivot jackshaft (2 zerks)
 - Attached elevator, if equipped (4 zerks)

Annually (every 250 hours)

-
- Replace hydraulic oil filter
- Replace engine oil and filter
- Replace engine fuel filter
- Inspect engine air filter (clean or replace)
- Inspect wheel hubs and re-pack with grease.
- Inspect engine fan and alternator belts
- Inspect air conditioning cabin air filter (If equipped)

Lubrication Points

Infeed Conveyor Chain (3 grease zerks; All Models)



Outer Live Deck Chain Idlers (6 zerks; 1820+/2220/2222)



Inner Live Deck Bearings (2 zerks on 1412 and 1412+; 3 zerks on 1520, 1520+, 1520+HP, 1820, 1820+, 2220, and 2222)



Saw Pivot Shaft (2 zerks; All models)



12' Attached Elevator (If equipped; 4 zerks, 2 upper & 2 lower)



Maintenance & General Servicing

NEVER PERFORM SERVICE PROCEDURES WHILE THE MACHINE IS RUNNING. ALWAYS STOP THE ENGINE, REMOVE THE KEY, AND DEPLOY YOUR LOCK OUT/TAG OUT PROCESS BEFORE SERVICING

DO NOT MODIFY THE MACHINE IN ANY WAY. UNAUTHORIZED MODIFICATIONS MAY IMPAIR THE FUNCTION AND/OR SAFETY OF THIS MACHINE.

- Disconnect the battery prior to performing any service. Do not leave tools on the battery or touching the terminals.
- Air tanks need to be drained prior to performing any maintenance. All pressure in the air, oil, and cooling system must be drained before any lines, fittings, or related items are removed or disconnected. Once the drain valves are opened, they should remain open until all maintenance is completed.
- The operator should understand all service procedures before doing the work.
- Be sure to conduct maintenance checks prior to each operation.
- Use proper cleaners to clean equipment. **DO NOT** use gasoline or other solvents.
- Do not touch an unguarded engine muffler or exhaust pipe while they are hot; severe burns could result.
- Be aware of any hot components when servicing equipment to avoid burns.
- Always use appropriate tools when servicing equipment.
- Rubber hoses will gradually age. Be sure to replace hoses at least every two years, whether worn or not.
- Keep all parts in good condition and properly installed. Make sure any damaged parts are repaired immediately. Ensure worn and/or broken parts are promptly replaced.
- The manufacturer recommends the use of ATF hydraulic oil or bar and chain oil in the reservoir that lubricates the bar and chain. This is to be monitored and filled as needed.
- Escaping hydraulic fluid under pressure has sufficient force to penetrate skin, causing serious personal injury.
- Remain alert for possible pressure when disconnecting any device from a system that uses pressure.
- **DO NOT** check for pressure leaks with your hands. High pressure oil can cause personal injury.
- Fluid escaping from pinholes may be invisible. Make sure a piece of cardboard or wood is used to search for suspected leaks. Wear eye protection when checking for leaks.
- If injured by escaping fluid, seek medical attention immediately.
- For servicing information regarding the engine, refer to the engine owner's manual.

Repairs & Adjustments:

- Keep the Blockbuster properly maintained and in good working order.
- **NEVER MAKE ADJUSTMENTS, REPAIRS, OR PERFORM MAINTENANCE WHILE THE**

MACHINERY IS RUNNING!

- Inspect your machinery if you feel a hazard has taken place or a jam has occurred.
- Make any necessary repairs prior to re-starting operations.
- Keep hands and body away from moving parts.
- Always make sure nuts, bolts, set screws, hoses, and other fittings are secure and in place. Under normal operations the machine's vibrations could cause these items to work loose.
- The manufacturer recommends that the operator applies their own Lock Out/Tag Out process, if needed, especially prior to performing any mechanical & electrical maintenance, or fixing any jams.
- Always ensure the measuring device is adjusted to your desired cutting length. Adjustments can be made in two-inch increments.

Cleaning:

- Always check your Blockbuster daily, for the buildup of sawdust, wood debris, etc. especially around the engine. It is important to keep your Blockbuster clean to reduce the risk of personal injury, risk of wood waste catching fire, covering of important gauges and safety decals, etc.
- **DO NOT USE** flammable solvents to clean your Blockbuster.
- When using high pressure water to clean your Blockbuster exercise caution while washing around wiring and other components such as safety decals. These parts of your Blockbuster, like parts on any piece of equipment, can become vulnerable to damage if they are exposed to extreme conditions they are not intended to withstand.

Storing:

- Allow the engine to sufficiently cool prior to being stored in any enclosed area.
- If storing the Blockbuster with fuel in the tank, **DO NOT** place it in an area where fumes may reach an open flame or spark.
- **DO NOT** store machines in a place where there are flammable materials, such as dry grass or straw.
- Properly clean your equipment prior to storing.
- When storing the machine for an extended period, be sure to remove the battery, adjust the electrolytes to the proper level, and store in a dry place.
- When storing the machine for long periods of time, it is recommended that the machine should be run every two to three months for approximately five minutes under no load, cycling all cylinders, orbit motors, and hydraulic components to assure proper lubrication.
- The battery will lose its charge while it is stored. Recharge it every two months, or as needed.
- Refer to the engine owner's manual for specific information when storing the engine.

Handling of Waste Products:

- Waste products such as used oil (engine & hydraulic), fuel, and grease can harm the environment if they are not properly disposed of.
- See your local recycling center to learn how to get rid of your waste products.
- A Material Safety Data Sheet (MSDS) provides specific details on chemical products: physical and health hazards, safety procedures, and emergency response techniques. Contact your dealer or the manufacturer for the MSDS on chemicals used with this machine.
- Always be aware of your environment and the ecosystem.

TROUBLESHOOTING

If you are experiencing a problem with your Blockbuster that is not listed or resolved from this chart, contact your dealer or the manufacturer.

UNLESS NECESSARY, NEVER MAKE ANY ADJUSTMENTS OR TROUBLESHOOTING STEPS WHILE THE MACHINE IS RUNNING.

IF	CHECK
Issues Pertaining to Engine	<ul style="list-style-type: none"> ▶ Refer to Engine Manual
Engine Not Cranking	<ul style="list-style-type: none"> ▶ Check for dead battery. ▶ Check for loose battery connections. ▶ Blown fuses ▶ Bad relays
Reason for Dead Battery	<ul style="list-style-type: none"> ▶ Check the breakaway switch for the electric brakes to ensure it is not removed. ▶ Key left in run position ▶ Other issues refer to Engine Manual
Hydraulic or Manual Log Deck Not Folding	<ul style="list-style-type: none"> ▶ Ensure the hydraulic pressure settings are correct. (Refer to Pressure Setting Section) ▶ Ensure the manual log deck pin has been removed. ▶ Check to ensure the log deck has not been damaged or bent. ▶ Ensure the hinge area is free of all foreign material. ▶ Ensure the hinge area is not binding or damaged.
Chain On Log Trough or Log Deck Not Moving	<ul style="list-style-type: none"> ▶ Check all sprockets, set screws, and keyways to make sure they are tight and in place. ▶ Make sure the roller chain is in place and properly tensioned. ▶ Check to ensure the hydraulics are working properly.
Hydraulic Chain Saw Not Lowering	<ul style="list-style-type: none"> ▶ Make sure the engine is running at the suggested operating speed. ▶ Make sure the air pressure is not too high. ▶ Ensure the hydraulic pressure setting is correct. (Refer to Pressure Setting Section) ▶ Release the cylinder pin and make sure the saw head bearings move freely. NEVER MAKE ANY ADJUSTMENTS TO THE SAW AREA WITHOUT SHUTTING THE MACHINE OFF SERIOUS INJURY COULD RESULT. ▶ Run cylinder out while pin is removed.

IF	CHECK
Engine crank – No Start	<ul style="list-style-type: none"> ▶ Ensure splitter and “Elev Run” are in neutral positions.
Hydraulic Chain Saw Not Raising	<ul style="list-style-type: none"> ▶ Check for the proper amount of air pressure. ▶ Ensure the hydraulic pressure setting is correct. (Refer to Pressure Setting Section) ▶ Release the cylinder pin and make sure the saw head bearings move freely. ▶ Ensure the saw head is free of all foreign material. ▶ NEVER MAKE ANY ADJUSTMENTS TO THE SAW AREA WITHOUT SHUTTING THE MACHINE OFF. SERIOUS INJURY COUW RESULT.
Chain Saw Will Not Cut Through Log	<ul style="list-style-type: none"> ▶ Check chain for dullness or damage. ▶ Check chain for proper, balanced sharpening ▶ Check to ensure the rails on the saw bar are not worn. ▶ Check to ensure the saw bar is not bent. ▶ Ensure saw chain is not on backwards
Chain Stops While Cutting Log	<ul style="list-style-type: none"> ▶ Ensure the hydraulic pressure setting is correct. (Refer to Pressure Setting page) ▶ Check chain tension. ▶ Lack of bar oil
Chain On Saw Will Not Move	<ul style="list-style-type: none"> ▶ Ensure saw valve mounting bolts are slightly loose. ▶ Remove the bottom cap on the saw MSL pilot valve and inspect for foreign material, damaged or over-compressed spring. ▶ Check bar tip, chain tension, & chain lubrication
Burned Paint or Bluish Discoloration on Guide-Bar Rail	<ul style="list-style-type: none"> ▶ Check to make sure chain is properly lubricated. ▶ Check to ensure the bars downward pressure is not too high. ▶ Check the chain’s sharpness. ▶ Check guide bar for possible replacement.
Discharge Chute Is Jammed	<ul style="list-style-type: none"> ▶ Check the chute for any obstructions.
Splitting Cylinder does not return	<ul style="list-style-type: none"> ▶ Check for the proper amount of air pressure. ▶ Ensure the plate slides by disconnecting the cylinder from the push plate. ▶ Ensure the splitting cylinder beam has no excess grease or oil that would attract sawdust or dirt. Causing a buildup that can stop the push plate from operating correctly. ▶ Bad one-way check on the splitter valve, non-functioning MSL for splitter
Splitter Head Will Not Adjust	<ul style="list-style-type: none"> ▶ Check actuating cylinder pins for proper placement. ▶ Ensure splitter head moves freely and is free of all foreign material.

IF	CHECK
Saw chain runs all the time	<ul style="list-style-type: none"> ▶ Check saw valve mounting bolts ▶ Remove bottom cap on MSL pilot valve, inspect for damage spring, etc.
Bar stuck in cut	<ul style="list-style-type: none"> ▶ Shut off engine. Use block of wood to push bar up (DO NOT USE YOUR HAND). Back pressure can make motor rotate when freed. ▶ Check bar for rail wear and cutting crooked

STANDARD EQUIPMENT & SPECIFICATIONS

*The manufacturer is not responsible for injuries or damage due to non-manufacturer approved equipment modifications or misuse of this equipment. The manufacturer's warranty is null & void if any unapproved modifications are made. The manufacturer's warranty is extended only to the original consumer purchaser.

Model	22-22	22-20	18-20	15-20	14-12
STANDARD MODEL EQUIPMENT					
Engine - Refer to Engine Manual	74HP Doosan Diesel	68HP Doosan Diesel	49HP Doosan Diesel	40HP Vanguard EFI Gas	40HP Vanguard EFI Gas
Hydraulic Powered Log Deck	Standard	Standard	Standard	Standard	Standard
Number of Log Deck Strands	3	3	3	3	2
Adj. Splitting Head - 4, 6, 8, or 12-way	4,6,8,12	4,6,8,12	4,6,8	4,6,8	4,6,8
Chain Driven Log trough	Standard	Standard	Standard	Standard	Standard
Hydraulic Saw	Standard	Standard	Standard	Standard	Standard
Hydraulic Stiff Legs	Standard	N/A	N/A	N/A	N/A
Air Compressor	X	X	X	N/A	N/A
Axle Type	Tandem	Single	Single	Single	Single
Electric Brakes	Standard	Standard	Standard	Standard	Standard
Safety Glasses	Standard	Standard	Standard	Standard	Standard
Transport Running Lights	Standard	Standard	Standard	Standard	Standard
Firewood Clean-out Grate	Standard	Standard	Standard	Standard	Standard
Toolbox	Standard	Standard	Standard	Standard	Standard
Operator's Seat	Standard	Standard	Standard	Standard	Standard

Model	1412+	1520+	1520+HP	1820+
STANDARD MODEL EQUIPMENT				
Engine - Refer to Engine Manual	40HP Vanguard EFI Gas	40HP Vanguard EFI Gas	49 HP Doosan Diesel	49 HP Doosan Diesel
Hydraulic Powered Log Deck	X	X	X	X
Number of Log Deck Strands	2	3	3	3
Adj. Splitting Head - 4, 6, or 8 way	4,6,8,12	4,6,8,12	4,6,8,12	4,6,8,12
Chain Driven Log trough	Standard	Standard	Standard	Standard
Hydraulic Saw	Standard	Standard	Standard	Standard
Hydraulic Stiff Legs	N/A	N/A	N/A	N/A
Air Compressor	N/A	N/A	N/A	X
Axle Type	Single	Single	Single	Single
Electric Brakes	Standard	Standard	Standard	Standard
Safety Glasses	Standard	Standard	Standard	Standard
Transport Running Lights	Standard	Standard	Standard	Standard
Firewood Clean-out Grate	Standard	Standard	Standard	Standard
Toolbox	Standard	Standard	Standard	Standard
Operator's Seat	Standard	Standard	Standard	Standard

STANDARD MODEL SPECS	22-22	22-20	18-20	15-20	14-12
Maximum Cutting Diameter	24" (60.96cm)	24" (60.96cm)	20" (50.8cm)	15" (38.1cm)	15" (38.1cm)
Maximum Log Length	24' (7.36m)	20' (6.1m)	20' (6.1m)	20' (6.1m)	14' (4.27m)
Splitting Length	12" -22" (30.9cm-61cm)	12" -22" (30.9cm-61cm)	12" -22" (30.5cm- 55.9cm)	12" -22" (30.5cm- 55.9cm)	12" -22" (30.5cm- 55.9cm)
In-Feed Log Trough	16' (4.88m)	14' (4.27m)	14' (4.27m)	14' (4.27m)	10' (3.04m)
Maximum Splitter Opening	30" (76.2cm)	30" (76.2cm)	24" (61cm)	24" (61cm)	24" (61cm)
Transporting Width	7'11" (2.41m)	8' (2.44m)	6'6" (1.98m)	6'6" (1.98m)	6'6" (1.98m)
Transporting Height	9' (2.74m)	8'4" (2.54m)	7' (2.13m)	6'6" (1.98m)	6'6" (1.98m)
Operating Width	13' (3.96m)	11' (3.35m)	8'6" (2.59m)	8'10" (2.69m)	8'10" (2.69m)
Operating Deck Height	5'5" (1.65m)	5' (1.52m)	5' (1.52m)	4' (1.22m)	4' (1.22m)

STANDARD MODEL SPECS	22-22	22-20	18-20	15-20	14-12
Length	26'6" (8.08m)	24'6" (7.47m)	22'10" (6.96m)	21'6" (6.55m)	17'6" (5.33m)
Weight (Approximate) Maximum Vertical Load (Newtons)	10,400 lbs. (4,717kg) 46,263.35N	7,400 lbs. (3,356kg) 32,918.15N	5,900 lbs. (3,676kg) 26,245.55N	3,280 lbs. (1,488kg) 14,590.75N	2,700 lbs. (1,224kg) 12,010.68N
Tongue Weight (Approximate) Maximum Torque Pull	1,040 lbs. (468kg) 4,626.33N	740 lbs. (333kg) 3,291.81N	590 lbs. (265.5kg) 2,624.56N	328 lbs., (147.6kg) 1,459.08N	270 lbs. (121.5k) 1,201.07N
Log Deck Length	10' (3.05m)	8' (2.44m)	5' (1.52m)	5' (1.52m)	5' (1.52m)
Hydraulic Tank Capacity	44gal* (166.6L)	33gal* (124.9L)	25 gal* (94.6L)	25 gal (94.6L)	25gal (94.6L)
Fuel Tank Capacity	25gal (94.6L)	25 gal (94.6L)	25 gal (94.6L)	12gal (45.4L)	12 gal (45.4L)
Towing Ball Size	2 5/16" (58.74mm)	2 5/16" (58.74mm)	2 5/16" (58.74mm)	2" (50.80m)	2" (50.80m)
Splitting Cylinder Size	5 inches	5 inches	4 inches	4 inches	4 inches
Splitter Cycle Time	4.5 sec	5 sec	5.5 sec	6.5 sec	6.5 sec
Production - Cords/Hour 128 Cubic Feet or 3.62 Cubic Meter	3-4+	2-3+	2+	1.5+	1+

STANDARD MODEL SPECS	1412+	1520+	1520+HP	1820+
Maximum Cutting Diameter	20" (50.8cm)	20" (50.8cm)	20" (50.8cm)	24" (60.96cm)
Maximum Log Length	14' (14.27m)	20' (6.1m)	20' (6.1m)	20' (6.1m)
Splitting Length	12" -22" (30.9cm- 61cm)	12" -22" (30.9cm- 61cm)	12" -22" (30.9cm- 61cm)	12" -22" (30.9cm- 61cm)
In-Feed Log Trough	10' (3.04m)	14' (4.27m)	14' (4.27m)	14' (4.27m)
Maximum Splitter Opening	24" (61cm)	24" (61cm)	24" (61cm)	30" (76.2cm)
Transporting Width	6'6" (1.98m)	6'6" (1.98m)	6'6" (1.98m)	8' (2.44m)
Transporting Height	6'6" (1.98m)	6'6" (1.98m)	6'6" (1.98m)	8'4" (2.54m)

Standard Model Specs	1412+	1520+	1520+HP	1820+
Operating Width	8'10"(2.69m)	8'10" (2.69m)	8'10" (2.69m)	11' (3.35m)
Operating Deck Height	4' (1.22m)	4' (1.22m)	4' (1.22m)	5' (1.52m)
Length	17'6" (5.33m)	21'6" (6.55m)	21'6" (6.55m)	24'6" (7.47m)
Weight (Approximate) Maximum Vertical Load (Newtons)	4,520 lbs.	5,240 lbs.	6,360 lbs.	7,100lbs
Tongue Weight (Approximate) Maximum Torque Pull	720 lbs.	N/A	1,160lbs.	N/A
Log Deck Length	5' (1.52m)	5' (1.52m)	5' (1.52m)	8' (2.44m)
Hydraulic Tank Capacity *Indicates hydraulic cooler is utilized	25gal (94.6L)	25gal (94.6L)	25gal* (94.6L)	33gal* (124.9L)
Fuel Tank Capacity	12 gal (45.4L)	12 gal (45.4L)	25 gal (94.6L)	25 gal (94.6L)
Towing Ball Size	2" (50.80m)	2" (50.80m)	2" (50.80m)	2 5/16" (58.74mm)
Splitting Cylinder Size	5 inches	5 inches	5 inches	5 inches
Splitter Cycle Time	7 sec	7 sec	7 sec	8 sec
Production - Cords/Hour 128 Cubic Feet or 3.62 Cubic Meter	1.5+	1.5+	2+	2.5+

END OF MANUAL